

Pump Service Kits

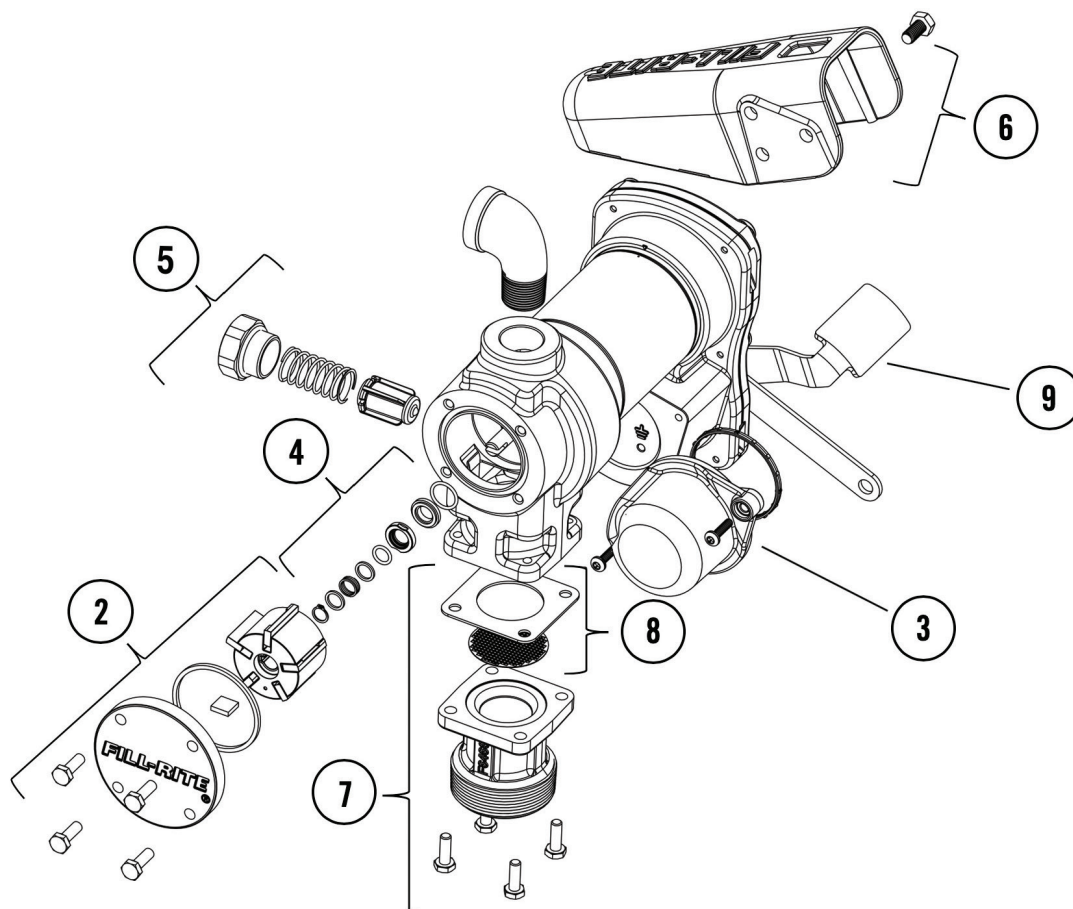

#	Kit	Description	Parts
1	KIT120BD*	BioDiesel Kit	O-ring, inlet and bypass cap seals, bypass valve poppet
2	KIT120RGG	Rotor and Vane Kit	Rotor cover, rotor, vanes, rotor key, O-ring seal, attaching hardware
3	KIT120JCH	Junction Cover Kit	Junction cover, seal, fasteners
4	KIT120SL	Seal Kit	O-ring, shaft seals, retainer clip
5	KIT120BV	Bypass Service Kit	Bypass valve, valve spring, bypass cap, O-ring seal
6	KIT120NB	Nozzle Boot Kit	Nozzle boot, attaching hardware
7	KIT120BG	Inlet Flange Kit	Inlet flange (bung), attaching hardware, inlet seal, screen
8	KIT120SG	Inlet Gasket and Screen	Gasket for inlet (bung) and screen
9	KIT120SWH	Switch Lever Kit	Switch lever, mounting hardware

*KIT120BD not called out in diagram above